



IDEAL FOR
 MULTI-SCREEN
 INSTALLATIONS

BT8390-VESA200T SYSTEM X™ UNIVERSAL INTERFACE ARMS WITH TILT FOR SMALL / MEDIUM SCREENS



Ideal for single row, multi-screen installations, these interface arms are designed to mount small to medium sized screens in a tilted position along System X horizontal mounting rails. The universal design is compatible with a variety of different screens and allows them to be mounted in either landscape or portrait orientations. Levelling screws on each interface arm provide post installation height adjustment and thumbwheels allow easy tool-less adjustment of the tilt angle up to 20°.

SPECIFICATION

Recommended screen size	up to 47"
Max load	70kg
VESA® & non-VESA fixings	up to 200mm* (vertical dimension)
Tilt adjustment	up to +20° (in increments of 5°)
Supplied in pairs	

*The VESA specification of the BT8390-VESA200T refers to the vertical dimension only. All System X interface arms can be positioned as far along the rail as necessary.

FEATURES

- Ideal for menu boards and other multi-screen installations
- Universal design compatible with most screens
- Suitable for landscape or portrait mounting
- Tool-less thumbwheels for easy adjustment of the tilt angle
- Lateral adjustment - position arms anywhere along the length of the rail
- Includes levelling screws to adjust the screen height
- Safety screws help prevent unauthorised removal of screens
- Simple 'hook-on' installation



47" 120cm VESA 200 50KG 20° SYSTEM X

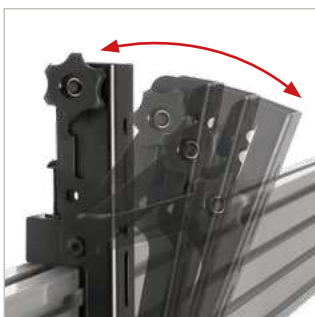

Tilt adjustment of up to +20° for enhanced overhead visibility



Arms feature levelling screws to adjust the screen height



Safety screws help prevent unauthorised removal of screens



Simple 'hook-on' installation

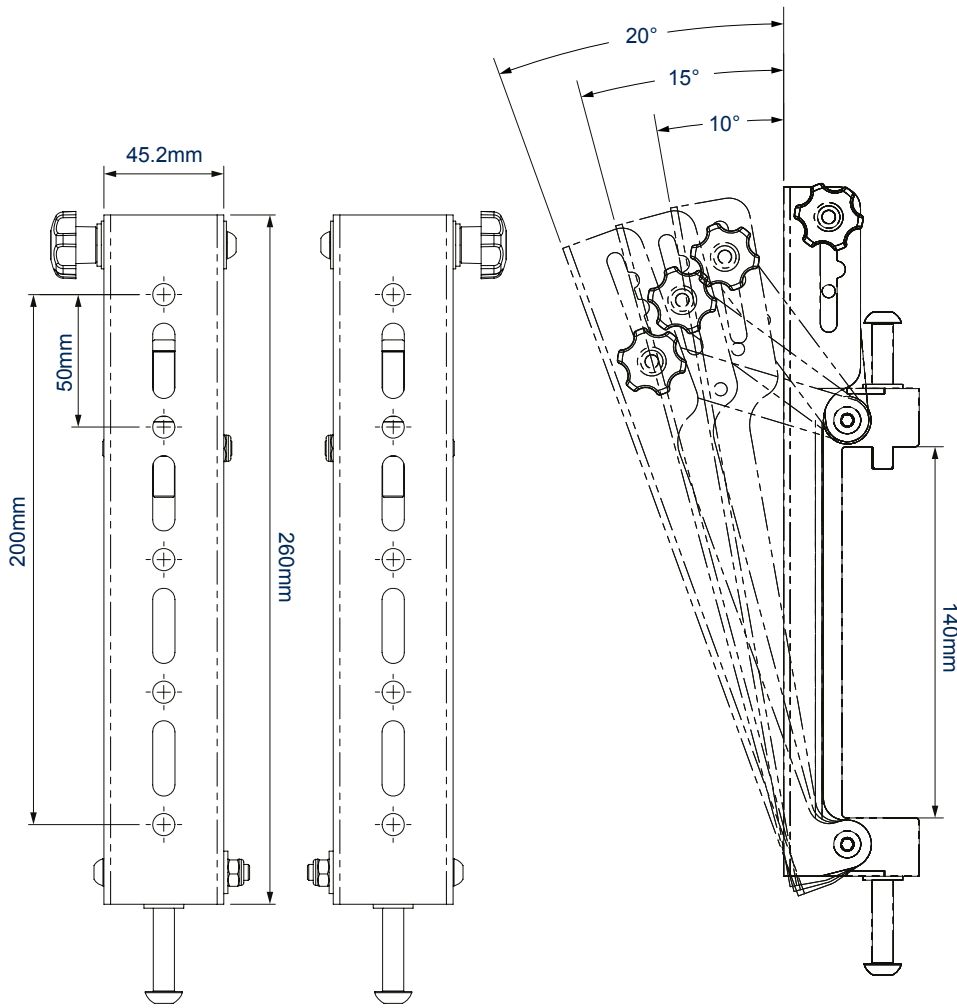

FRONT VIEW

SIDE VIEW WITH TILT

TYPICAL INSTALLATIONS

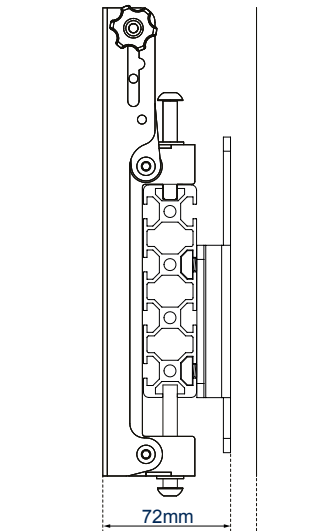

WALL MOUNTED*

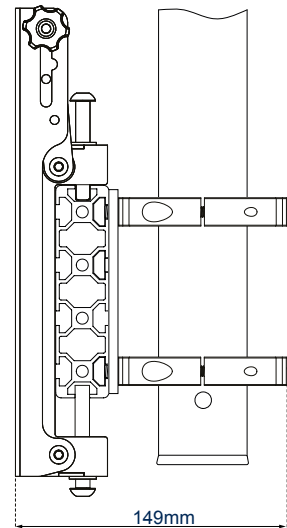

POLE MOUNTED*

*Please note all other components shown in the technical drawings are available separately.

PACKING INFORMATION

COLOUR:	ORDER REF:	EAN CODE:	MASTER CARTON QTY:	INNER CARTON QTY:	MASTER CARTON WEIGHT:	MASTER CARTON CUBE:
Black	BT8390-VESA200T/B	5019318501227	7	0	13.5kg	0.065cbm

ACCESSORIES AND RELATED PRODUCTS

BT8390-WFK2



Wall Fixing Kits are used to fix mounting rails securely to the wall

BT8390-030/050/070/150/175/200



Mounting Rails can be attached to columns, walls or poles using System X components

BT8390-EXT



Extension Kits combine mounting rails together to create longer installations

BT8390-VESA200F



VESA 200 Interface Arms are designed to mount small - medium sized screens in a fixed vertical position to mounting rails

© 2019 B-Tech AV Mounts. All rights reserved. The information in this specification sheet reflects the current technical specifications as the time of print. We warrant the fit to the technical specifications without liability. B-Tech AV Mounts is a registered trademark of B-Tech AV Mounts. All other trademarks are the property of their respective owners. B-Tech AV Mounts is not liable for loss or damage caused by improper installation or use. Any reproduction or transmission of any part of this specification is strictly prohibited unless prior written permission has been granted by B-Tech AV Mounts. European Trademark No.: 002741256-0024 SS-V2-BT8390-VESA200T-020819